



REGIONAL TRANSPORT AGENT



Since 2017
TRUSTED WITH CARGO





DELIVERY WITHIN RUSSIA

- Nationwide coverage
- Multimodal transportation
- Warehouse services



INTERNATIONAL DELIVERY

- Procurement of goods in China and Europe
- Export to China and other countries
- Import through neighboring countries: goods of all sizes, border clearance assistance
- Multimodal transportation



CONTAINERS FOR RENT AND SALE

- 5-ton (the smallest), 20-foot, 40-foot and 45-foot (the largest)
- Specialized container options

PROCUREMENT OF GOODS IN CHINA AND EUROPE



RTA provides a full range of services for the procurement and delivery of goods from Europe and China. We handle commercial, customs, and logistics tasks, guaranteeing timely and secure delivery.

Our company takes care of all stages of the process, from purchase to delivery at the destination.

- Procurement of goods from your suppliers
- Foreign currency transactions
- Route planning and optimization

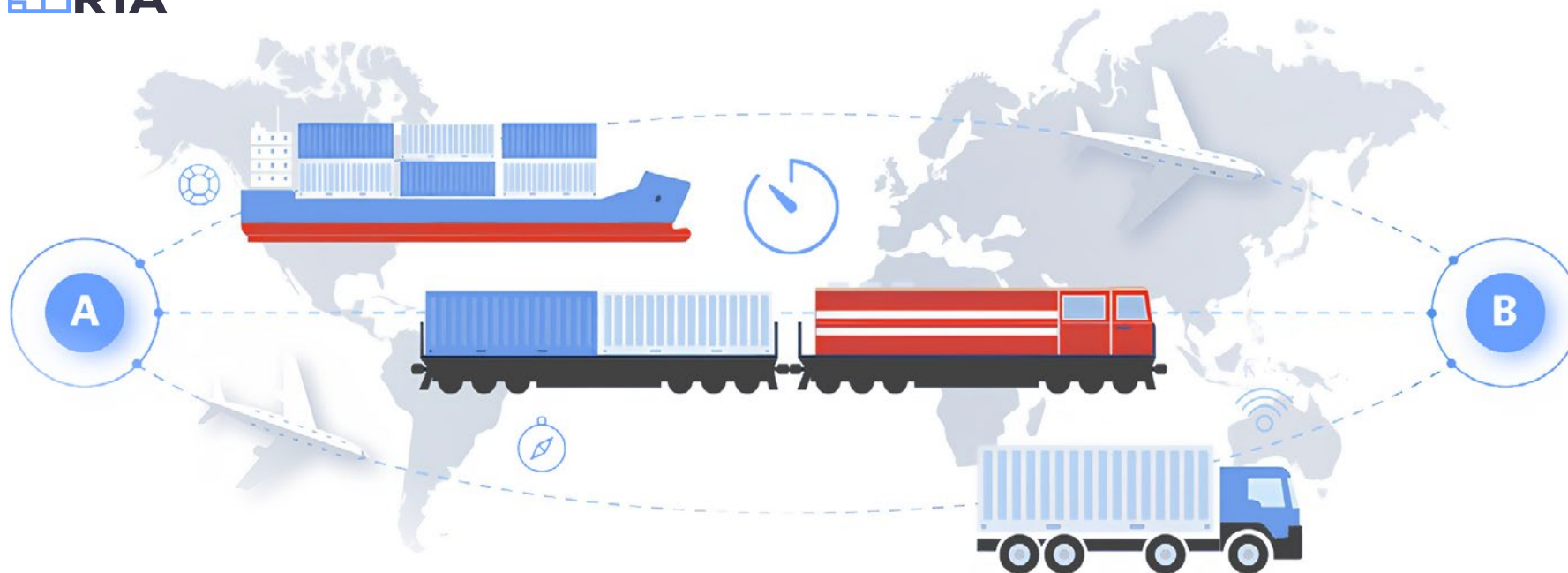

INTERNATIONAL DELIVERY

- Plan routes meticulously.
- Develop solutions for fragile, oversized, and standard/non-standard cargo.
- Calculate and estimate costs, including terminal handling charges.
- Provide advice on document preparation for crossing the borders of the EAEU and countries outside the Customs Union.

DELIVERY WITHIN RUSSIA



RTA's primary shipping operations are based in Moscow, St. Petersburg, Novosibirsk, and Vladivostok.

However, we are ready to arrange delivery **from any city** in Russia.

We prefer use multimodal transportations if it's more economic and faster moving of goods with different vehicles.

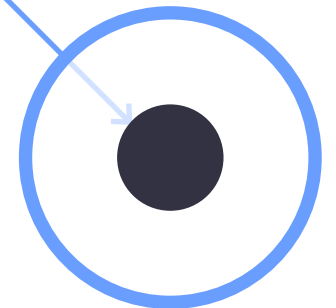

CONTAINERS FOR RENT AND SALE

Our company offers services for the purchase and sale of rail containers in Russia, China, and Europe.

Our managers will help you find the right container for your goods.

For one-time shipments or for use over a specific period, it is more cost-effective to rent a container than to buy one.

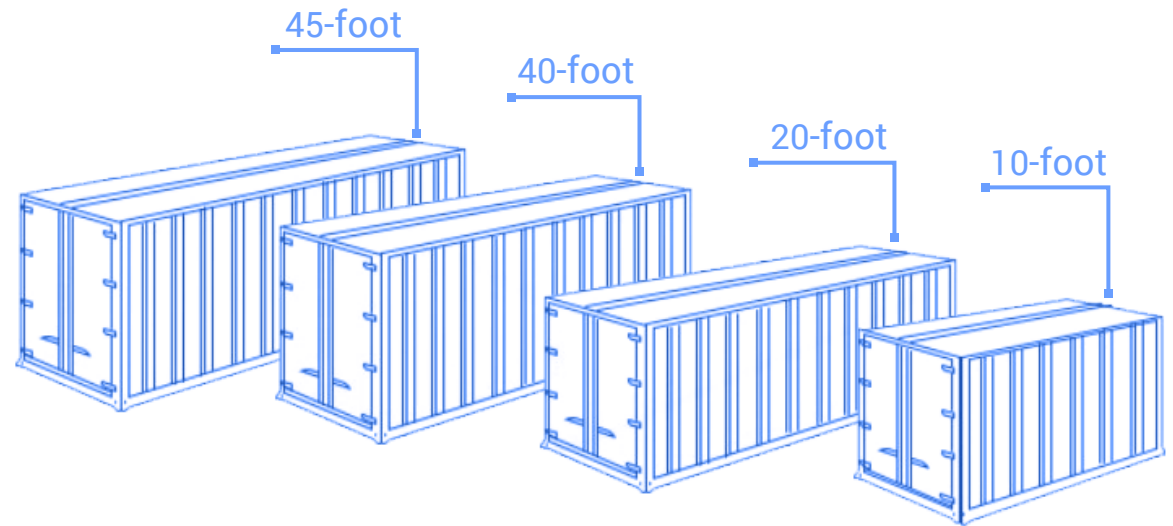

Containers come in several common sizes:

5-ton (the smallest), **20-foot**, **40-foot** and **45-foot** (the largest).

The smallest, 5-ton container, is ideal for shipping small quantities of goods or for personal storage. For large-scale shipments, a 40 or 45-foot container should be used.

In addition to standard containers, you can also rent specialized containers: **refrigerated container** (reefer), **tank container**, **insulated container**, **dry cargo container**.



WAREHOUSE SERVICE



8 Shamotnaya St., Podolsk, Moscow Region



Operating hours: **8:00 AM - 9:00 PM**



Area: **1300 sq. meters, heated**

SERVICES INCLUDE:

- heated warehouse storage and consolidation
- loading all types of cargos on the adjacent territory
- cross-docking
- loading and securing of the oversized cargo
- dunnage and insulation for rail containers

RTA's warehouse is located in a secure, **guarded area with 24/7 video surveillance.**

We can simultaneously service **up to 10 vehicles at our loading dock.**

The adjacent territory provides **enough space for handling and storing oversized cargo.**





Since 2017
TRUSTED WITH CARGO

DELIVERING TILES AND BRICKS UNDAMAGED TO THE RUSSIAN FAR EAST

Each pallet of bricks and asphalt tiles weighs over 1200 kg. This is close to the maximum weight limits, and not all securing methods can withstand such loads. We utilize the most robust fastenings available to ensure the cargo arrives intact. We consider both the duration of the journey and the potential for tilting during container loading and unloading. The photos demonstrate our commitment to protecting clients cargo.





Since 2017
TRUSTED WITH CARGO

SPECIALIZED HANDLING FOR OVERSIZED CARGOS

We can handle any cargo –
we'll figure out the best way to load it!

Our team often secures challenging items like gas cylinders, heavy equipment parts, spools, and other non-standard freight in containers. Our experience allows us to understand and prevent potential transport issues using cushioning materials, bracing, and specialized inserts.



 rtarus.com  info@rtarus.com



Since 2017
TRUSTED WITH CARGO

VEHICLE SHIPPING IN CONTAINERS

While shipping cars may seem simple, there are important details.

Incorrect securing can cause damage, from tire rub from straps to body damage.

We secure each vehicle with extreme care, as if it were our own.

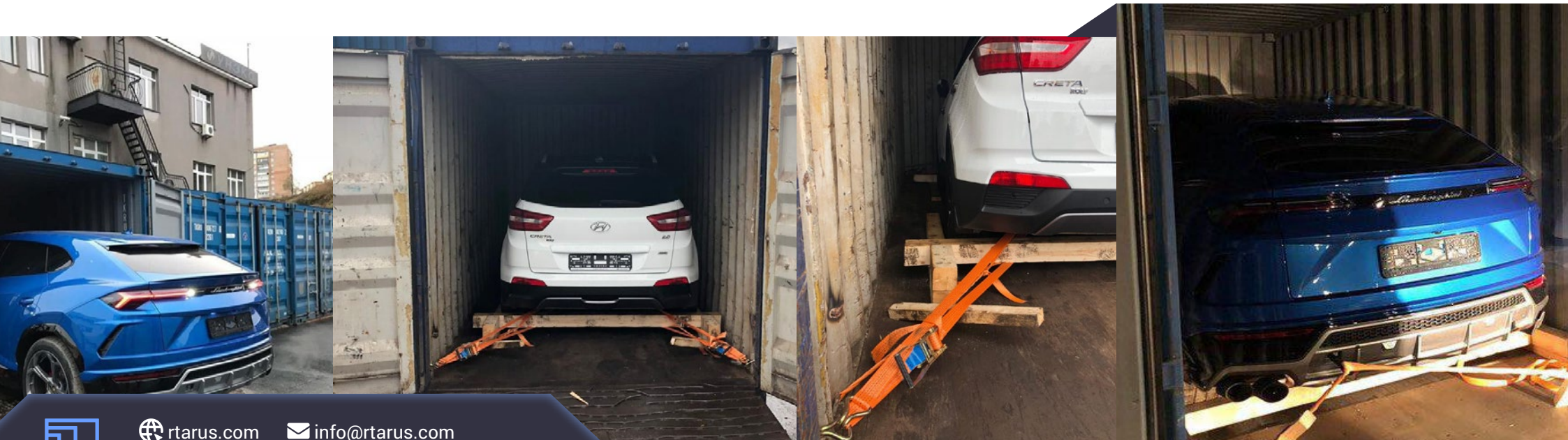



Since 2017
TRUSTED WITH CARGO

BUILDING MATERIAL CONSOLIDATION EXPERTISE

RTA has been handling building material deliveries since 2020.

We have learned to minimize damage to goods during delivery to the client's location.

Building materials pose unique challenges. Irregular packaging sometimes prevents filling containers completely, but we always find ways to safely load all items requested by the client.

Thanks to our precise calculations and expertise in transport logistics, we use minimal packing materials, saving our clients money.





Since 2017
TRUSTED WITH CARGO

FOOD PRODUCT DELIVERY

We've been specializing
in food product transportation during 5 years.

Our consolidation experience allows us to accurately calculate the required amount of packing materials, minimizing the risk of packaging damage.

Our expertise in handling various cargo types reduces consolidation costs for our clients.



ALCOHOLIC BEVERAGE SHIPPING

We have developed methods to protect glass-bottled products during all seasons as well. In summer, container temperatures can soar up to 30-50°C. That's why we add layers of insulation when packing to lower the temperature for products, and creating a thermos-like effect.

We use minimal packing material, and our precise calculations allow the client to save money. Products arrive at their destination unspoiled by heat and with no bottle or packaging damage.

In winter container loading is performed with the optimal amount of packing material. RTA also provides container insulation services, using 1, 2, or 3 layers of foam insulation. This service is offered at our facility to avoid delays during the container loading process. All operations are carried out swiftly, and the cargo is dispatched to the client's warehouse.

Our precise calculations result in reduced additional costs for clients when shipping consolidated cargo.





Since 2017
TRUSTED WITH CARGO

EXPORT CARGO DELIVERY TO CHINA

Shipments from Moscow to China are growing rapidly.

We have a track record of successful shipments, including a shipment of “Nitrogen” and “Carbon” in a container train consisting of 65x40-foot containers, as well as a shipment of “Rubber” in 76x40-foot containers.

We load cargo quickly and carefully, and we arrange for shipment within the shortest time possible.



OUR PROCESS





153 Leninsky Prospekt,
SetlCenter business center, office 1020,
Saint Petersburg, 196247



+7 (812) 740-34-44 info@rtarus.com

 rtarus.com

